

APPROVALS



 **ENGINEERING CODE**
268EA47

 **APPROVED REFRIGERANT**
R-134a

 **POWER SUPPLY**
220-240 V 50 Hz

 **STANDARD CONDITIONS**
ASHRAE

 **APPLICATION**
LBP

 **COOLING CAPACITY**
190 W (LBP)

 **EFFICIENCY**
1.41 W/W (LBP)

 **MOTOR TYPE**
RSIR/RSCR

 **STARTING TORQUE**
LST

DATA

General Data

Type	Hermetic reciprocating
Technology Type	On-Off
Displacement	7.37 cm ³
Compressor Cooling	Static/NotControlled/220
Expansion Device	Capillary Tube
Horse Power	1/5 hp
Max Condensing Pressure Operating	13.92 bar
Max Condensing Pressure Peak	15.62 bar
Power Supply	220-240 V 50 Hz
Evaporating Temperature Range	-30 °C to -5 °C

Electrical Data

Motor type	RSIR/RSCR
Starting Torque	LST
Start Winding Resistance	17.6 Ω at 25° C
Run Winding Resistance	13.2 Ω at 25° C

Mechanical Data

Maximum Recommended Refrigerant Charge	350 g
Oil Charge	350 ml
Oil Type Configuration	ESTER
Oil Type Viscosity	ISO22
Pressurization	Dry air charge
Weight	10.8 Kg
Free Internal Volume	2.1 L

Electrical Components

	Description
Starting Device	PTC V230
Run Capacitor	4
Motor Protection	T0503/07

External Characteristics

Base Plate	European	
Tray Holder	Yes	
Height	200 mm	
Connector	Internal Diameter	Shape
Suction	6.1 mm	Slanted 42°/Copper
Discharge	4.94 mm	Slanted parallel to Base Plate/Copper
Process	6.1 mm	Slanted 42°/Copper

PERFORMANCE

Rated Points

Condensing Temperature	Evaporating Temperature	Cooling Capacity	Power Consumption	Current	Gas Flow Rate	Efficiency
54.40°C	-23.30°C	190 W	135 W	0.61 A	3.69 kg/h	1.41 W/W

Test Condition: ASHRAELBP32, Static/NotControlled/220, Return Gas 32.2°C, Evaporation -23.30°C, Condensing 54.40°C, Ambient 32.2°C, Liquid 32.2°C, Subcooling 22.2K. Data in accordance to EN

12900:2013 and AHRI 540:2015 polynomial equation and uncertainty guidance.

Performance Curve Data

Condensing Temperature 35°C

Evaporating Temperature °C	Cooling Capacity W	Power W	Current A	Gas Flow Rate kg/h	Efficiency W/W
-30	152	99	0.48	2.94	1.53
-25	203	115	0.54	3.93	1.77
-20	266	131	0.61	5.18	2.03
-15	343	149	0.68	6.70	2.31
-10	435	166	0.76	8.50	2.62
-5	541	182	0.85	10.63	2.97

Test Condition: ASHRAELBP32, Static/NotControlled/220, Return Gas 32.2°C, Ambient 32.2°C, Liquid 32.2°C. Data in accordance to EN 12900:2013 and AHRI 540:2015 polynomial equation and uncertainty guidance.

Condensing Temperature 45°C

Evaporating Temperature °C	Cooling Capacity W	Power W	Current A	Gas Flow Rate kg/h	Efficiency W/W
-30	141	102	0.48	2.73	1.38
-25	191	121	0.56	3.70	1.57
-20	252	142	0.64	4.90	1.78
-15	326	164	0.73	6.36	2
-10	414	185	0.83	8.09	2.23
-5	516	206	0.94	10.12	2.5

Test Condition: ASHRAELBP32, Static/NotControlled/220, Return Gas 32.2°C, Ambient 32.2°C, Liquid 32.2°C. Data in accordance to EN 12900:2013 and AHRI 540:2015 polynomial equation and uncertainty guidance.

Condensing Temperature 55°C

Evaporating Temperature °C	Cooling Capacity W	Power W	Current A	Gas Flow Rate kg/h	Efficiency W/W
-25	171	126	0.58	3.31	1.35
-20	230	150	0.68	4.47	1.53
-15	302	176	0.79	5.88	1.72
-10	386	201	0.91	7.55	1.92
-5	483	226	1.05	9.49	2.14

Test Condition: ASHRAELBP32, Static/NotControlled/220, Return Gas 32.2°C, Ambient 32.2°C, Liquid 32.2°C. Data in accordance to EN 12900:2013 and AHRI 540:2015 polynomial equation and uncertainty guidance.

Operating Envelope

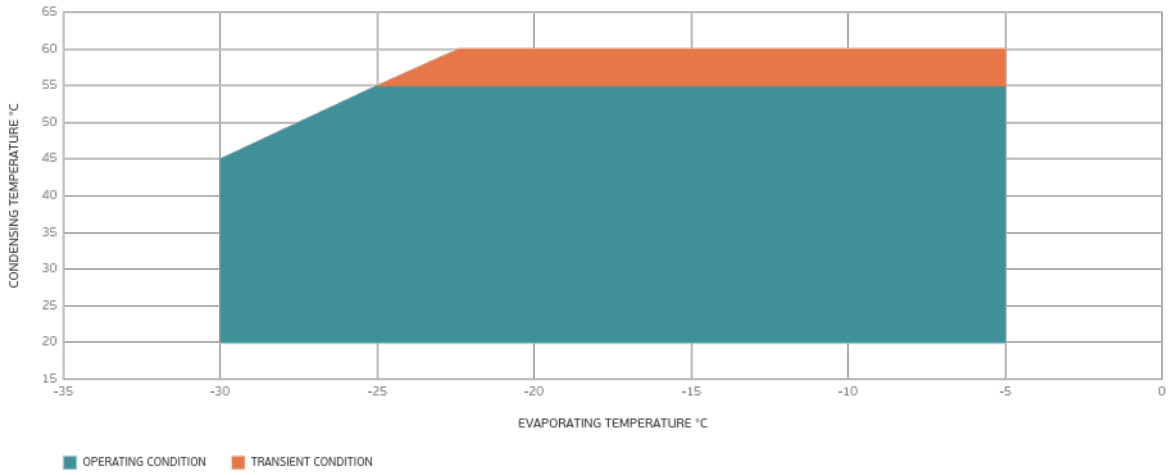

External Dimensions

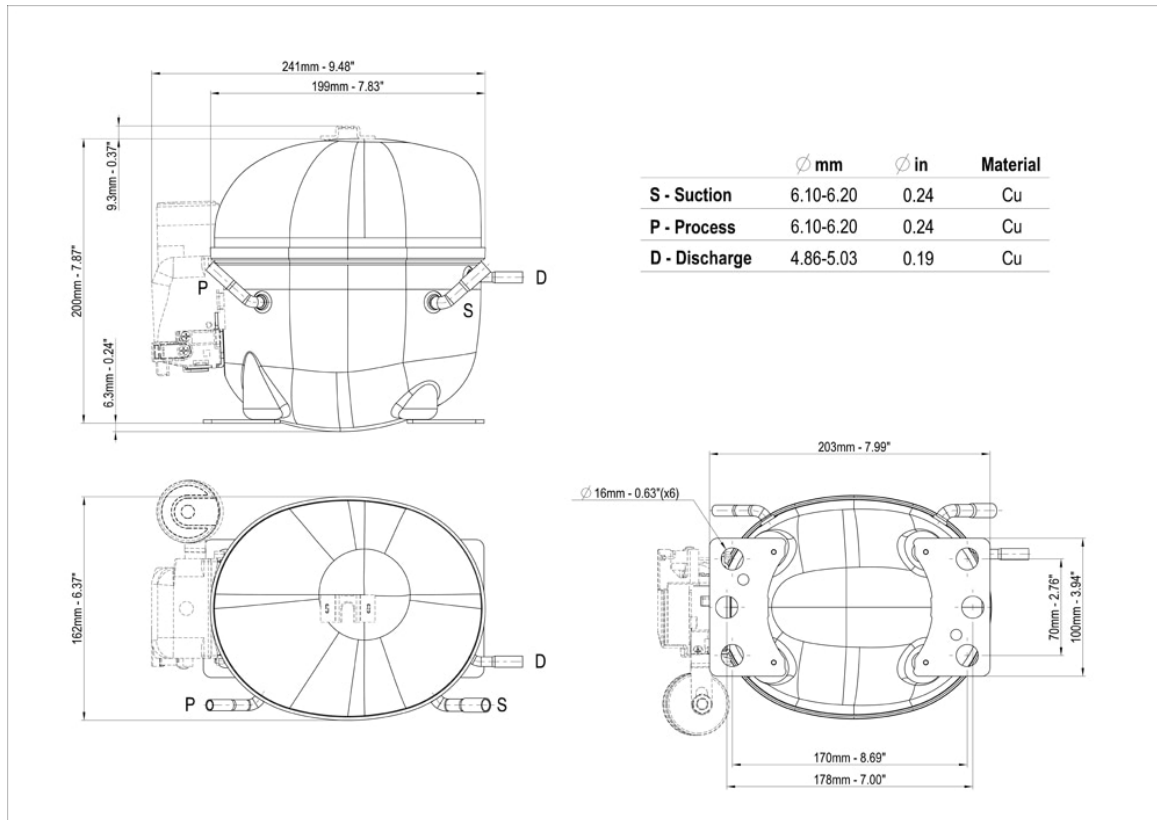

Wiring Diagram

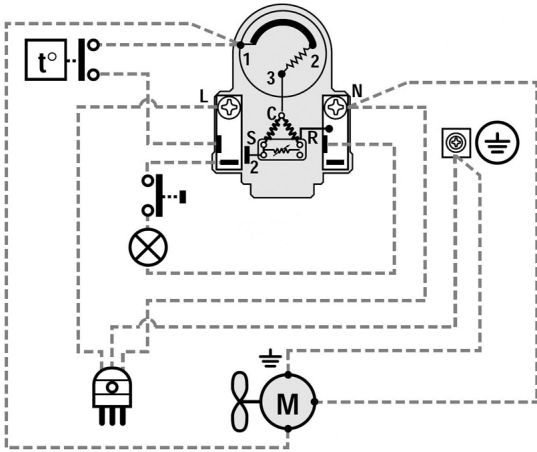

Assembly Instructions

