

APPROVALS



ENGINEERING CODE
922DN04

APPROVED REFRIGERANT
R-404A

POWER SUPPLY
200-240 V 50 Hz

STANDARD CONDITIONS
ASHRAE

APPLICATION
LBP

COOLING CAPACITY
653 W (LBP)

EFFICIENCY
1.34 W/W (LBP)

MOTOR TYPE
CSCR

STARTING TORQUE
HST

DATA

General Data

Type	Hermetic reciprocating
Technology Type	On-Off
Displacement	14.5 cm ³
Compressor Cooling	Fan/NotControlled/200
Fan Air Flow	520 m ³ /h
Expansion Device	Capillary Tube or Expansion Valve
Horse Power	3/4 hp
Max Condensing Pressure Operating	24.71 bar
Max Condensing Pressure Peak	27.71 bar
Power Supply	200-240 V 50 Hz / 230 V 60 Hz
Evaporating Temperature Range	-40 °C to -10 °C

Electrical Data

Motor type	CSCR
Starting Torque	HST
Start Winding Resistance	10.4 Ω at 25° C
Run Winding Resistance	2.4 Ω at 25° C

Mechanical Data

Maximum Recommended Refrigerant Charge	800 g
Oil Charge	450 ml
Oil Type Configuration	ESTER
Oil Type Viscosity	ISO22
Pressurization	Dry air charge
Weight	17 Kg
Free Internal Volume	3.3 L

Electrical Components

	Description
Run Capacitor	15
Start Capacitor	88-108 Uf / 330 V
CSR / CSIR Box	YES
Starting Device	RVA4M3C-109
Motor Protection	MRP30APK-3261

External Characteristics

Base Plate	Universal	
Tray Holder	No	
Height	220 mm	
Connector	Internal Diameter	Shape
Suction	9.6 mm	Vertical/Copper
Discharge	6.42 mm	Vertical/Copper
Process	6.42 mm	Vertical/Copper

PERFORMANCE

Rated Points

Condensing Temperature	Evaporating Temperature	Cooling Capacity	Power Consumption	Gas Flow Rate	Efficiency
54.40°C	-23.30°C	653 W	487 W	15.12 kg/h	1.34 W/W

Test Condition: ASHRAELBP32, Fan/NotControlled/200, Return Gas 32.2°C, Evaporation -23.30°C, Condensing 54.40°C, Ambient 32.2°C, Liquid 32.2°C, Subcooling 22.2K. Data are an indication of performance based simulation.

Performance Curve Data

Condensing Temperature 35°C

Evaporating Temperature °C	Cooling Capacity W	Power W	Gas Flow Rate kg/h	Efficiency W/W
-40	312	297	7.16	1.05
-35	424	343	9.76	1.24
-30	559	387	12.90	1.44
-25	719	430	16.68	1.67
-20	909	473	21.17	1.92
-15	1129	516	26.46	2.19
-10	1382	560	32.63	2.47

Test Condition: ASHRAELBP32, Fan/NotControlled/200, Return Gas 32.2°C, Ambient 32.2°C, Liquid 32.2°C. Data are an indication of performance based simulation.

Condensing Temperature 45°C

Evaporating Temperature °C	Cooling Capacity W	Power W	Gas Flow Rate kg/h	Efficiency W/W
-35	373	341	8.57	1.09
-30	506	397	11.66	1.28
-25	664	452	15.36	1.47
-20	849	506	19.75	1.68
-15	1065	561	24.92	1.9
-10	1314	616	30.95	2.13

Test Condition: ASHRAELBP32, Fan/NotControlled/200, Return Gas 32.2°C, Ambient 32.2°C, Liquid 32.2°C. Data are an indication of performance based simulation.

Condensing Temperature 55°C

Evaporating Temperature °C	Cooling Capacity W	Power W	Gas Flow Rate kg/h	Efficiency W/W
-30	438	403	10.06	1.09
-25	593	466	13.68	1.27
-20	774	528	17.97	1.47
-15	986	591	23.02	1.67
-10	1229	654	28.91	1.88

Test Condition: ASHRAELBP32, Fan/NotControlled/200, Return Gas 32.2°C, Ambient 32.2°C, Liquid 32.2°C. Data are an indication of performance based simulation.

Operating Envelope



External Dimensions

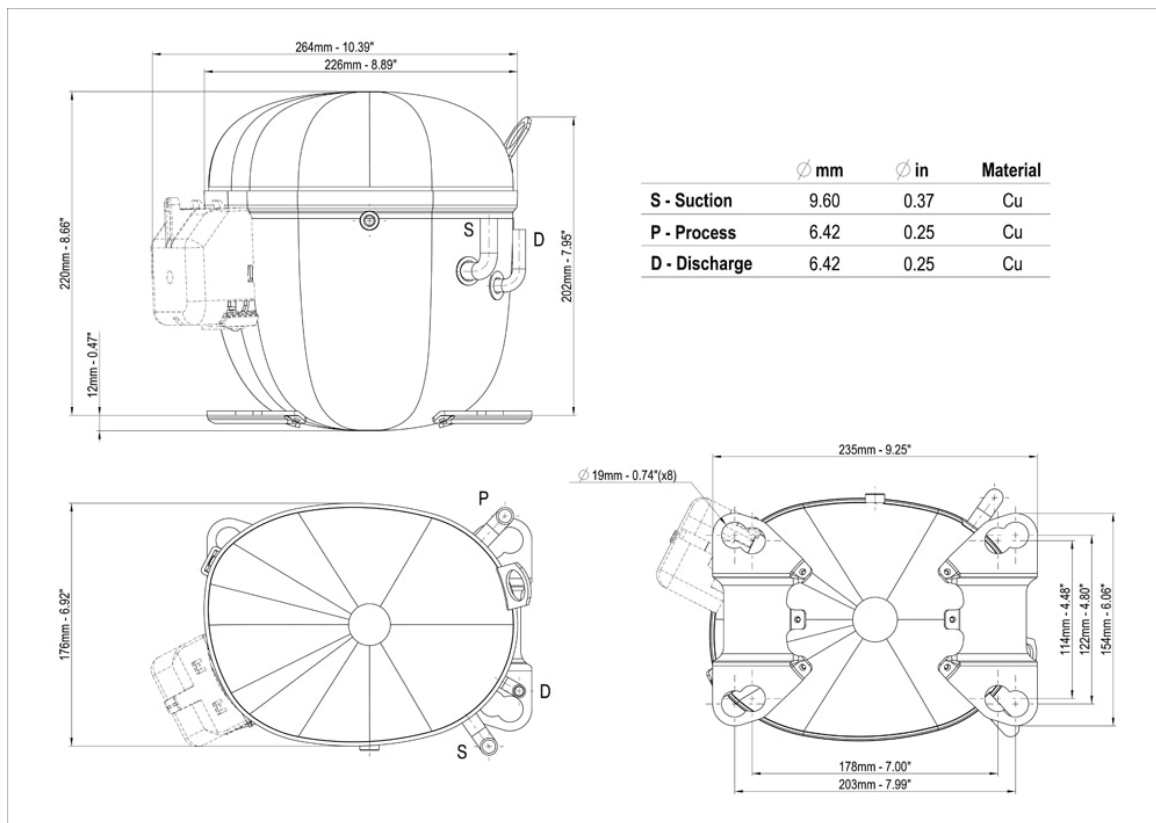

Wiring Diagram

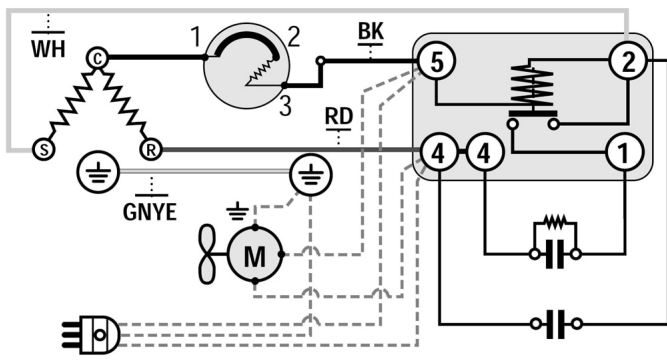

Assembly Instructions

