

Model

Designation	GS26MLX	220-240V/50Hz 1~	Sales code:	107B0503
-------------	----------------	------------------	-------------	-----------------

Compressor design

Oil type	Polyolester	Refrigerant(s)	R404A, R507, R452A
Oil viscosity	32,5cST	Displacement	26,3cm ³ / 1,6cu.in
Oil quantity	902cm ³ / 30,5fl.oz	Compressors on pallet	48
Refr. charge - tech. limit	2000g / 70,5oz		
Free gas volume comp.	3670cm ³ / 124,1fl.oz		
Weight	21,4kg / 47,2lbs		
Motor protection	1# internal		
Winding resistance main	1,8Ω (at 25°C)		
Winding resistance aux	8,1Ω (at 25°C)		
Max. winding temp.			
Max. discharge temp.	120°C / 248°F		



General - Configurations with GS26MLX

	Conf. 1	Conf. 2	Conf. 3	Conf. 4
Motorconfiguration	CSCR	CSCR	CSCR	CSCR
Power supply (nominal)	220-240V/50Hz	220-240V/50Hz	220-240V/50Hz	220-240V/50Hz
Number of phases	1	1	1	1
Voltage range	198-254V	198-254V	198-254V	198-254V
Approvals	VDE, CCC, EAC	VDE, CCC, EAC		
Starting torque	HST	HST	HST	HST
Note	Cover, clamp, gasket: pre-assembled to compressor.			

Applications with GS26MLX

	Conf. 1	Conf. 2	Conf. 3	Conf. 4
Refrigerant	R404A	R452A	R448A	R449A
Application	MBP	MBP	MBP	MBP
System cooling	fan 3m/s	fan 3m/s	fan 3m/s	fan 3m/s
Hot gas defrost	OK	OK	OK	OK
Long interval pull down	OK	OK	OK	OK

Electrical data - Configurations with GS26MLX

	Conf. 1	Conf. 2	Conf. 3	Conf. 4
Starting device type	relay	relay	relay	relay
Run capacitor	15μF	15μF	15μF	15μF
Start capacitor	80μF	80μF	80μF	80μF
LRA (locked rotor amps / 4s)	35A	35A	35A	35A
RLA (rated load amps / 1s)	6,4A	6,4A	6,4A	6,4A
Cut in current	35A	35A	35A	35A

Model

Designation

GS26MLX

220-240V/50Hz 1~

Sales code:

107B0503

Compressor dimensions

Housing	A Height	279mm / 10,98in
	B Height	267mm / 10,51in
	C Length shell	224mm / 8,82in
	D Length w. cover	232mm / 9,13in
	E Width	173mm / 6,81in

Connectors		Suction	Discharge	Process
		X	Y	Z
Diameter	[mm]	øi 16,03-16,13	øi 6,45-6,55	øi 6,4-6,6
	(i:inside, o:outside) [in]	øi 0,63-0,64	øi 0,25-0,26	øi 0,25-0,26
Material		copper	copper	copper
Horizontal angle	±2°	0°	0°	0°
Vertical angle	±2°	90°	71°	90°
Position l/h/w	[mm]	-95/234/-84	-105/84/-84	95/234/84
	[in]	-3,7/9,2/-3,3	-4,1/3,3/-3,3	3,7/9,2/3,3
Straight tube l.	[mm]	18	19	15
	[in]	0,7	0,7	0,6

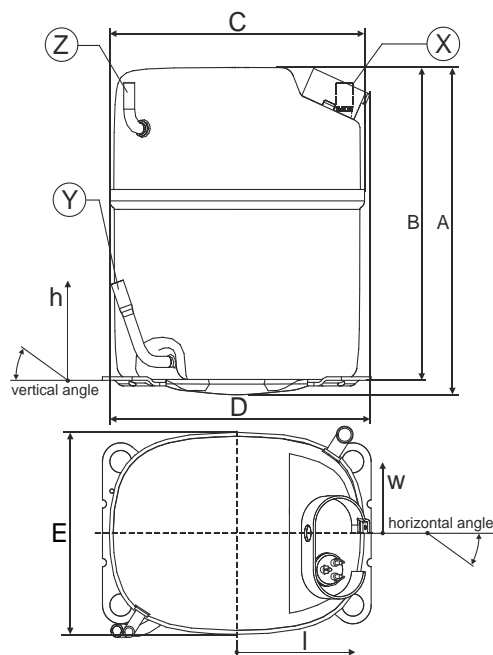

Compressor fixation

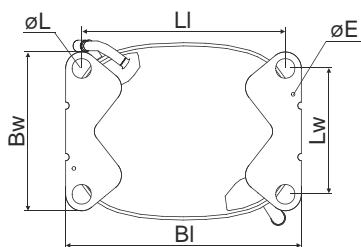

Baseplate	[mm]	[inch]
BI	235	9.25
Bw	154	6.06
øE	ø 3.6	ø 0.14

Large holes	[mm]	[inch]
LI	203	7.99
LW	122	4.80
øL	ø 19	ø 0.75

Bolt joint

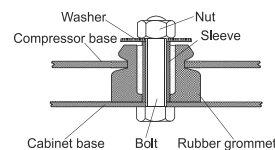

Mounting accessories

Bolt joint | M8 | ø19mm

one comp.

107B9150

Model

Designation	GS26MLX	220-240V/50Hz	Conf. 1	Sales code:	107B0503
-------------	----------------	----------------------	----------------	-------------	-----------------

Configuration

Motorconfiguration	CSCR
Power supply (nominal)	220-240V/50Hz 1~
Refrigerant	R404A
Application	MBP
Voltage range	198-254V
Starting torque	HST
Approvals	VDE
	CCC
	EAC

Electrical accessories / wiring diagram

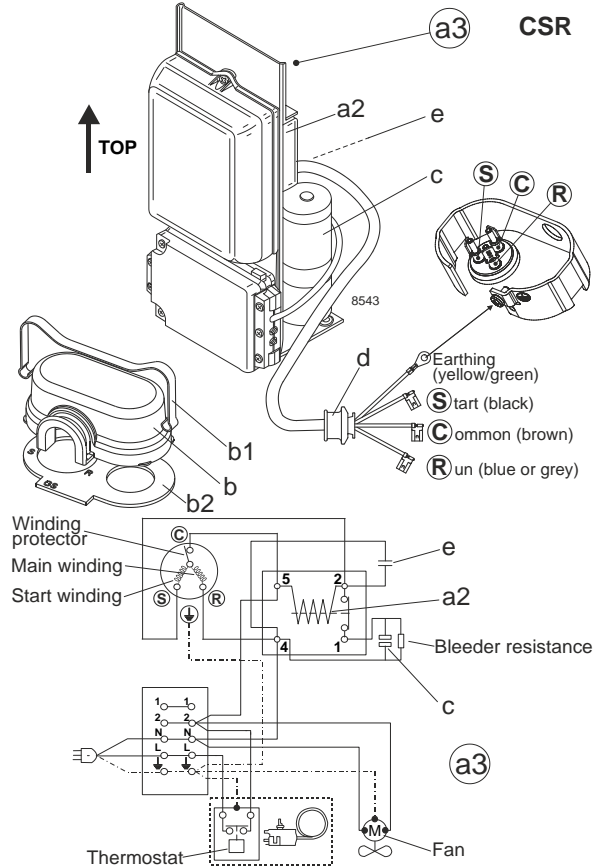

Ambient temperatures / system cooling

Ambient temperature min.:	10°C / 50°F
Ambient temperature max.:	38°C / 101°F

System cooling (n/a: outside limits)

T ambient	LBP	MBP	HBP
32°C / 90°F	n/a	fan 3m/s	n/a
38°C / 100°F	n/a	fan 3m/s	n/a
43°C / 110°F	n/a	n/a	n/a

Operation pressure range

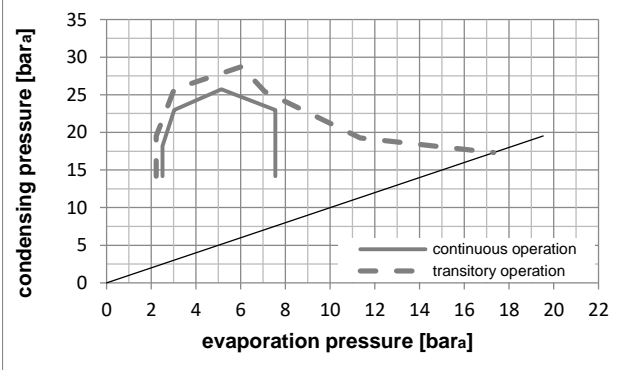
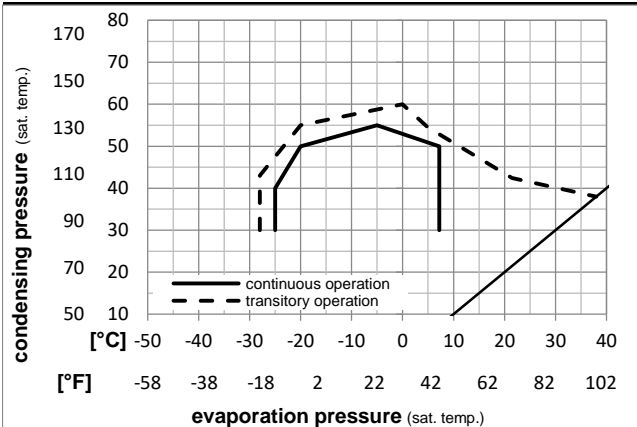

Components (cover, clamp, gasket: pre assembled)

a3	GS starter kit (600mm)	117-7072
b	cover	107B9101
b2	gasket	107B9100
b1	clamp	107B9104

Model

Designation	GS26MLX	220-240V/50Hz	Conf. 1	Sales code:	107B0503
-------------	----------------	----------------------	----------------	-------------	-----------------

Optimization + standard conditions

R404A, 220V/50Hz, CSCR, fan 3m/s, VDE, CCC, EAC

Evaporating pressure (saturation temperature)					Condensing pressure (saturation temperature)					Power consumption				
					Return gas temp.					Current consumption				
					Liquid temp.					Ref. mass flow				
					Cooling capacity					COP EER				
					P1					I m				
	pe	pc	RGT	Tliq	[W]	[Btu/h]	[kcal/h]	[W/W]	[Btu/Wh]	[kcal/Wh]	[W]	[A]	[kg/h]	
[°C]	-6,66	54,4	35	46,1	2395,2	8180	2061,3	1,72	5,87	1,48	1393,3	6,82	65,90	ASHRAE MBP
[°F]	20	130	95	115										
[°C]	-10	55	32	55	1779,3	6077	1531,3	1,36	4,63	1,17	1312,4	6,45	56,96	cecomaf MBP
[°F]	14	131	89,6	131										
[°C]	-10	45	20	45	2123,6	7252	1827,6	1,75	5,98	1,51	1213,2	6,05	63,97	EN12900 MBP
[°F]	14	113	68	113										
[°C]	-6,66	48,9	18,3	48,9	2203,3	7525	1896,2	1,66	5,67	1,43	1327,3	6,57	72,00	ARI540 MBP
[°F]	20	120	65	120										
[°C]	-10	45	32	45	2253,8	7697	1939,6	1,86	6,34	1,60	1213,2	6,05	62,06	opt
[°F]	14	113	89,6	113										
[°C]	-25	45	32	45	1093,1	3733	940,7	1,25	4,27	1,08	873,4	4,58	29,49	opt
[°F]	-13	113	89,6	113										

Performance tables

R404A, 220V/50Hz, CSCR, fan 3m/s, VDE, CCC, EAC

	pe	Cooling capacity			COP	EER	P1	I	m		
	[°C]	[°F]	[W]	[Btu/h]	[kcal/h]	[W/W]	[Btu/Wh]	[kcal/Wh]	[W]	[A]	[kg/h]
[°C / °F]	-25	-13	1093,1	3733	940,7	1,25	4,27	1,08	873,4	4,58	29,49
cond. pressure	-20	-4	1426,4	4871	1227,6	1,44	4,91	1,24	992,8	5,07	38,70
pc= 45/113	-15	5	1810,5	6183	1558,1	1,64	5,59	1,41	1105,3	5,56	49,46
return gas temp.	-10	14	2253,8	7697	1939,6	1,86	6,34	1,60	1213,2	6,05	62,06
RGT= 32/90	-5	23	2764,5	9441	2379,2	2,10	7,16	1,80	1318,8	6,55	76,85
liquid temp	0	32	3351,0	11444	2883,9	2,35	8,03	2,02	1424,4	7,06	94,21
Tliq= 45/113	7,2	45	4345,5	14841	3739,8	2,75	9,39	2,37	1581,2	7,80	124,61
[°C / °F]	-25	-13	822,4	2809	707,8	0,93	3,18	0,80	882,2	4,70	25,70
cond. pressure	-20	-4	1102,9	3767	949,1	1,07	3,64	0,92	1034,1	5,27	34,70
pc= 55/131	-15	5	1419,1	4846	1221,3	1,21	4,12	1,04	1176,7	5,86	45,00
return gas temp	-10	14	1779,3	6077	1531,3	1,36	4,63	1,17	1312,4	6,45	56,96
RGT= 32/90	-5	23	2191,9	7486	1886,4	1,52	5,19	1,31	1443,4	7,04	70,95
liquid temp	0	32	2665,2	9102	2293,7	1,70	5,79	1,46	1572,0	7,64	87,40
Tliq= 55/131	7,2	45	3470,1	11851	2986,4	1,97	6,74	1,70	1757,8	8,51	116,46

Model

Designation	GS26MLX	220-240V/50Hz	Conf. 2	Sales code:	107B0503
-------------	----------------	----------------------	----------------	-------------	-----------------

Configuration

Motorconfiguration	CSCR
Power supply (nominal)	220-240V/50Hz 1~
Refrigerant	R452A
Application	MBP
Voltage range	198-254V
Starting torque	HST
Approvals	VDE CCC EAC

Electrical accessories / wiring diagram

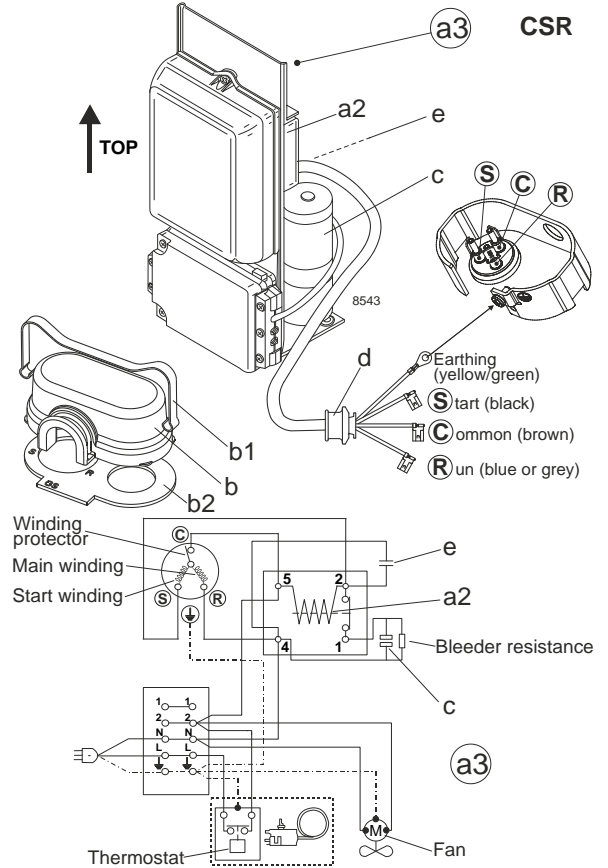

Ambient temperatures / system cooling

Ambient temperature min.:	10°C / 50°F
Ambient temperature max.:	38°C / 101°F

System cooling (n/a: outside limits)			
T ambient	LBP	MBP	HBP
32°C / 90°F	n/a	fan 3m/s	n/a
38°C / 100°F	n/a	fan 3m/s	n/a
43°C / 110°F	n/a	n/a	n/a

Operation pressure range

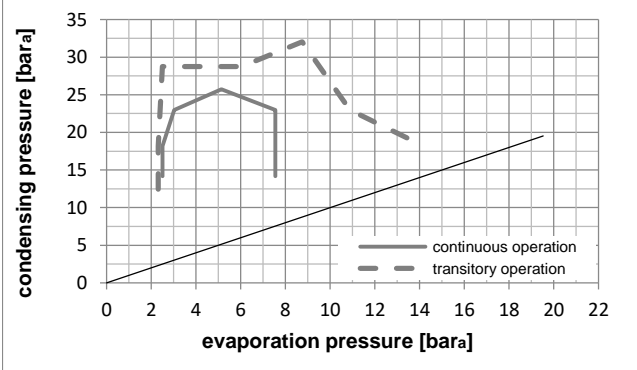
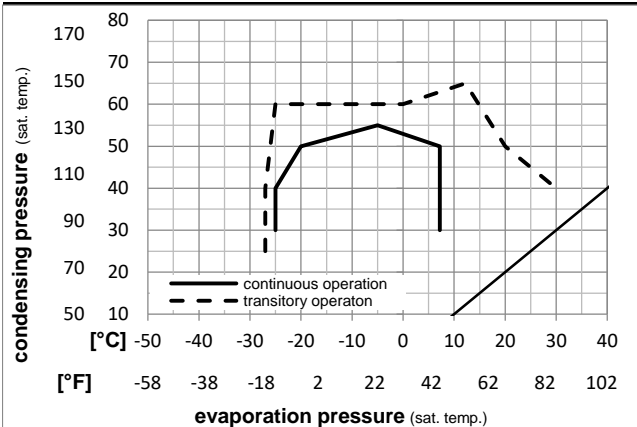

Components (cover, clamp, gasket: pre assembled)

a3	GS starter kit (600mm)	117-7072
b	cover	107B9101
b2	gasket	107B9100
b1	clamp	107B9104

Model

Designation **GS26MLX 220-240V/50Hz** Conf. 2 Sales code: **107B0503**

Optimization + standard conditions

R452A, 220V/50Hz, CSCR, fan 3m/s, VDE, CCC, EAC

Evaporating pressure (saturation temperature)					Condensing pressure (saturation temperature)						Power consumption			ASHRAE MBP	
					Return gas temp.			Liquid temp.			Current consumption				Ref. mass flow ṁ
					Cooling capacity			COP	EER	P1	I				
pe	pc	RGT	Tliq		[W]	[Btu/h]	[kcal/h]	[W/W]	[Btu/Wh]	[kcal/Wh]	[W]	[A]	[kg/h]		
[°C]	-6,7	54,4	35	46,1	2185,0	7462	1880,5	1,65	5,64	1,42	1323,2	6,53	61,47	ASHRAE MBP	
[°F]	20	130	95	115											
[°C]	-10	55	32	55	1641,6	5606	1412,8	1,33	4,54	1,15	1233,5	6,14	53,35	cecomaf MBP	
[°F]	14	131	89,6	131											
[°C]	-10	45	20	45	1988,9	6792	1711,6	1,76	5,99	1,51	1133,0	5,70	61,11	EN12900 MBP	
[°F]	14	113	68	113											
[°C]	-6,7	48,9	18,3	48,9	2042,3	6975	1757,6	1,63	5,56	1,40	1254,9	6,23	67,75	ARI540 MBP	
[°F]	20	120	65	120											
[°C]	-10	45	32	45	2107,5	7198	1813,8	1,86	6,35	1,60	1133,0	5,70	59,38	opt	
[°F]	14	113	89,6	113											
[°C]	-25	45	32	45	1011,6	3455	870,6	1,27	4,33	1,09	797,8	4,22	27,98	opt	
[°F]	-13	113	89,6	113											

Performance tables

R452A, 220V/50Hz, CSCR, fan 3m/s, VDE, CCC, EAC

	pe		Cooling capacity			COP	EER	P1	I	m	
	[°C]	[°F]	[W]	[Btu/h]	[kcal/h]	[W/W]	[Btu/Wh]	[kcal/Wh]	[W]	[A]	[kg/h]
[°C / °F]	-25	-13	1011,6	3455	870,6	1,27	4,33	1,09	797,8	4,22	27,98
cond. pressure	-20	-4	1355,4	4629	1166,5	1,50	5,12	1,29	904,7	4,69	37,69
pc= 45/113	-15	5	1713,7	5853	1474,9	1,69	5,76	1,45	1016,9	5,19	47,94
return gas temp.	-10	14	2107,5	7198	1813,8	1,86	6,35	1,60	1133,0	5,70	59,38
RGT= 32/90	-5	23	2557,9	8736	2201,3	2,04	6,98	1,76	1251,4	6,22	72,68
liquid temp	0	32	3085,8	10539	2655,7	2,25	7,69	1,94	1370,6	6,74	88,57
Tliq= 45/113	7,2	45	4024,9	13746	3463,8	2,61	8,92	2,25	1540,5	7,49	117,58
[°C / °F]	-25	-13	775,4	2648	667,4	0,97	3,33	0,84	795,9	4,21	24,68
cond. pressure	-20	-4	1047,3	3577	901,3	1,11	3,80	0,96	940,6	4,85	33,52
pc= 55/131	-15	5	1329,0	4539	1143,7	1,22	4,18	1,05	1087,0	5,50	42,84
return gas temp	-10	14	1641,6	5606	1412,8	1,33	4,54	1,15	1233,5	6,14	53,35
RGT= 32/90	-5	23	2006,2	6852	1726,6	1,46	4,97	1,25	1378,7	6,78	65,85
liquid temp	0	32	2443,9	8346	2103,2	1,61	5,49	1,38	1521,1	7,41	81,15
Tliq= 55/131	7,2	45	3244,9	11082	2792,6	1,89	6,45	1,63	1718,2	8,27	109,98

Model

Designation	GS26MLX	220-240V/50Hz	Conf. 3	Sales code:	107B0503
-------------	----------------	----------------------	----------------	-------------	-----------------

Configuration

Motorconfiguration	CSCR
Power supply (nominal)	220-240V/50Hz 1~
Refrigerant	R448A
Application	MBP
Voltage range	198-254V
Starting torque	HST
Approvals	

Electrical accessories / wiring diagram

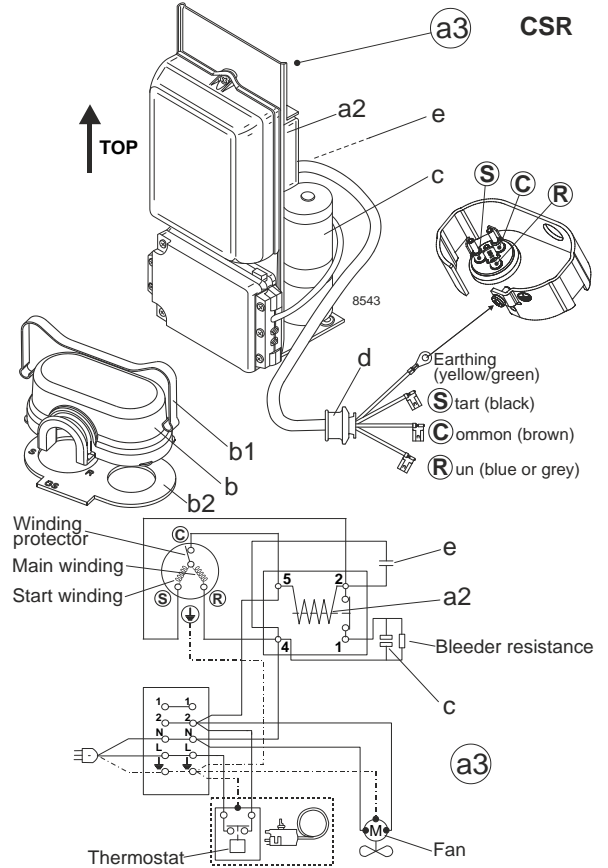

Ambient temperatures / system cooling

Ambient temperature min.:	10°C / 50°F
Ambient temperature max.:	38°C / 101°F

System cooling (n/a: outside limits)

T ambient	LBP	MBP	HBP
32°C / 90°F	n/a	fan 3m/s	n/a
38°C / 100°F	n/a	fan 3m/s	n/a
43°C / 110°F	n/a	n/a	n/a

Operation pressure range

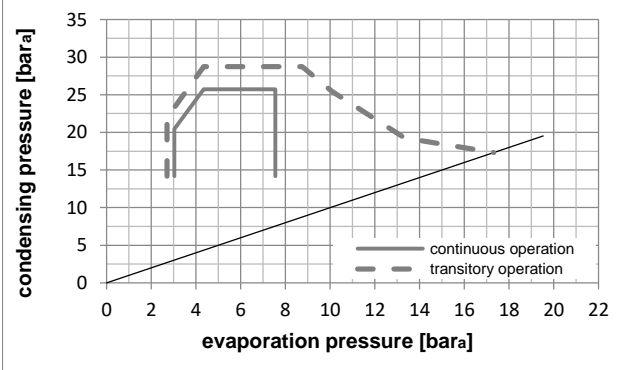
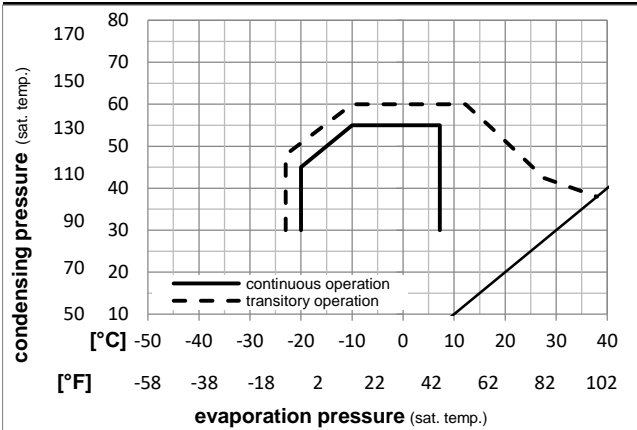

Components (cover, clamp, gasket: pre assembled)

a3	GS starter kit (600mm)	117-7072
b	cover	107B9101
b2	gasket	107B9100
b1	clamp	107B9104

Model

Designation **GS26MLX 220-240V/50Hz** Conf. 3 Sales code: **107B0503**

Optimization + standard conditions

R448A, 220V/50Hz, CSCR, fan 3m/s,

		Evaporating pressure (saturation temperature)				Condensing pressure (saturation temperature)					Power consumption				
		Return gas temp.				Liquid temp.					Current consumption			Ref. mass flow	
		Cooling capacity				COP	EER	P1	I	m					
		pe	pc	RGT	Tliq	[W]	[Btu/h]	[kcal/h]	[W/W]	[Btu/Wh]	[kcal/Wh]	[W]	[A]	[kg/h]	
[°C]	-6,66	54,4	35	46,1	2180,4	7447	1876,5	1,77	6,05	1,52	1231,7	6,12	47,63	ASHRAE MBP	
[°F]	20	130	95	115											
[°C]	-10	55	32	55	1662,7	5678	1431,0	1,44	4,92	1,24	1155,2	5,79	40,72	cecomaf MBP	
[°F]	14	131	89,6	131											
[°C]	-10	45	20	45	1957,8	6686	1684,9	1,82	6,23	1,57	1073,8	5,44	45,80	EN12900 MBP	
[°F]	14	113	68	113											
[°C]	-6,66	48,9	18,3	48,9	2086,3	7125	1795,5	1,77	6,05	1,52	1177,7	5,89	51,89	ARI540 MBP	
[°F]	20	120	65	120											
[°C]	-10	45	32	45	2037,3	6958	1753,3	1,90	6,48	1,63	1073,8	5,44	44,52	opt	
[°F]	14	113	89,6	113											
[°C]	-25	45	32	45	937,9	3203	807,2	1,25	4,26	1,07	751,3	4,05	20,17	opt	
[°F]	-13	113	89,6	113											

Performance tables

R448A, 220V/50Hz, CSCR, fan 3m/s,

	pe	Cooling capacity				COP	EER	P1	I	m	
	[°C]	[°F]	[W]	[Btu/h]	[kcal/h]	[W/W]	[Btu/Wh]	[kcal/Wh]	[W]	[A]	[kg/h]
[°C / °F]	-20	-4	1248,3	4263	1074,3	1,44	4,93	1,24	863,9	4,54	26,96
cond. pressure	-15	5	1611,6	5504	1387,0	1,66	5,67	1,43	970,8	5,00	35,00
pc= 45/113	-10	14	2037,3	6958	1753,3	1,90	6,48	1,63	1073,8	5,44	44,52
return gas temp.	-6,7	20	2356,9	8049	2028,4	2,07	7,06	1,78	1140,6	5,73	51,75
RGT= 32/90	-5	23	2534,7	8656	2181,4	2,16	7,37	1,86	1174,7	5,87	55,80
liquid temp	0	32	3113,1	10632	2679,2	2,44	8,34	2,10	1275,2	6,31	69,13
Tliq= 45/113	7,2	45	4107,5	14028	3534,9	2,89	9,86	2,48	1423,0	6,94	92,65
[°C / °F]	-20	-4	992,7	3390	854,3	1,11	3,78	0,95	896,0	4,68	24,00
cond. pressure	-15	5	1302,6	4449	1121,0	1,27	4,32	1,09	1028,7	5,25	31,68
pc= 55/131	-10	14	1662,7	5678	1431,0	1,44	4,92	1,24	1155,2	5,79	40,72
return gas temp	-6,7	20	1932,5	6600	1663,1	1,56	5,34	1,35	1236,3	6,14	47,58
RGT= 32/90	-5	23	2082,5	7112	1792,2	1,63	5,57	1,40	1277,5	6,32	51,43
liquid temp	0	32	2571,3	8781	2212,9	1,84	6,29	1,58	1397,1	6,83	64,13
Tliq= 55/131	7,2	45	3415,3	11664	2939,2	2,18	7,44	1,87	1568,6	7,57	86,68

Model

Designation	GS26MLX	220-240V/50Hz	Conf. 4	Sales code:	107B0503
-------------	----------------	----------------------	----------------	-------------	-----------------

Configuration

Motorconfiguration	CSCR
Power supply (nominal)	220-240V/50Hz 1~
Refrigerant	R449A
Application	MBP
Voltage range	198-254V
Starting torque	HST
Approvals	

Electrical accessories / wiring diagram

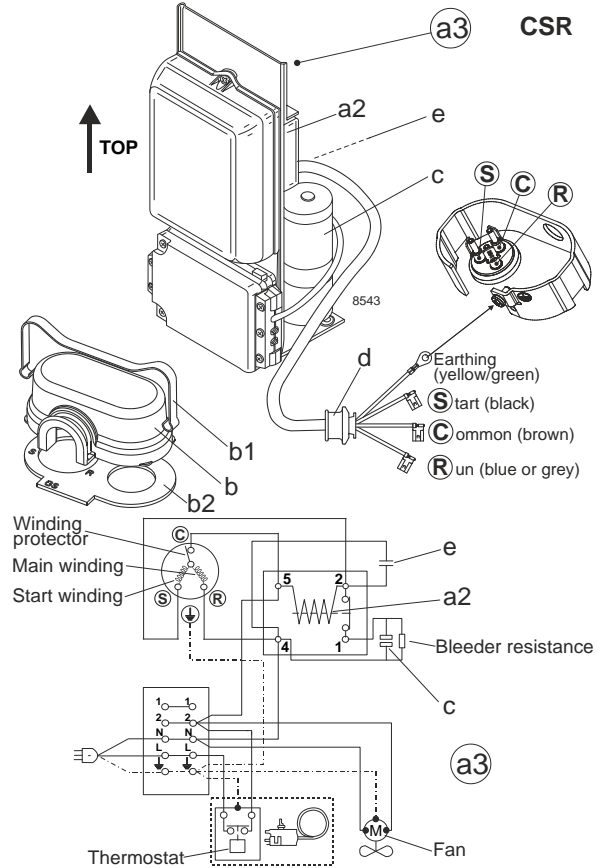

Ambient temperatures / system cooling

Ambient temperature min.:	10°C / 50°F
Ambient temperature max.:	38°C / 101°F

System cooling (n/a: outside limits)

T ambient	LBP	MBP	HBP
32°C / 90°F	n/a	fan 3m/s	n/a
38°C / 100°F	n/a	fan 3m/s	n/a
43°C / 110°F	n/a	n/a	n/a

Operation pressure range

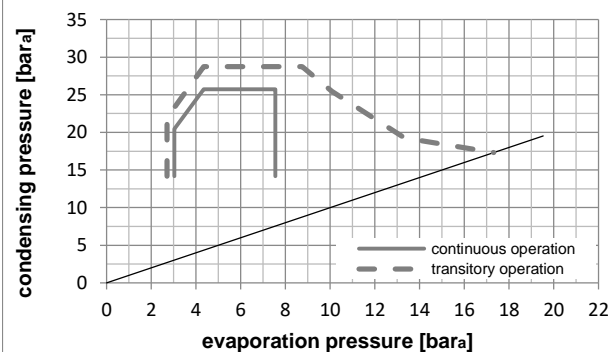
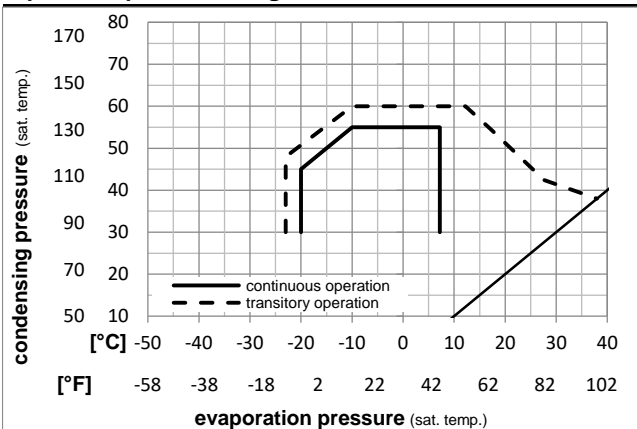

Components (cover, clamp, gasket: pre assembled)

a3	GS starter kit (600mm)	117-7072
b	cover	107B9101
b2	gasket	107B9100
b1	clamp	107B9104

Model

Designation **GS26MLX 220-240V/50Hz** Conf. 4 Sales code: **107B0503**

Optimization + standard conditions

R449A, 220V/50Hz, CSCR, fan 3m/s,

		Evaporating pressure (saturation temperature)				Condensing pressure (saturation temperature)					Power consumption					
											Current consumption					
		Return gas temp.				Cooling capacity					COP	EER	P1	I	Ref. mass flow	
		Liquid temp.													m	
		pe	pc	RGT	Tliq	[W]	[Btu/h]	[kcal/h]	[W/W]	[Btu/Wh]	[kcal/Wh]	[W]	[A]	[kg/h]		
[°C]	-6,66	54,4	35	46,1	2168,8	7407	1866,5	1,77	6,05	1,52	1224,8	6,09	48,31	ASHRAE MBP		
[°F]	20	130	95	115												
[°C]	-10	55	32	55	1651,9	5641	1421,6	1,44	4,91	1,24	1149,4	5,76	41,31	cecomaf MBP		
[°F]	14	131	89,6	131												
[°C]	-10	45	20	45	1945,1	6643	1674,0	1,82	6,21	1,57	1069,2	5,42	46,45	EN12900 MBP		
[°F]	14	113	68	113												
[°C]	-6,66	48,9	18,3	48,9	2070,9	7072	1782,2	1,77	6,04	1,52	1171,6	5,86	52,63	ARI540 MBP		
[°F]	20	120	65	120												
[°C]	-10	45	32	45	2026,2	6920	1743,8	1,90	6,47	1,63	1069,2	5,42	45,15	opt		
[°F]	14	113	89,6	113												
[°C]	-25	45	32	45	934,2	3190	804,0	1,25	4,26	1,07	749,4	4,04	20,48	opt		
[°F]	-13	113	89,6	113												

Performance tables

R449A, 220V/50Hz, CSCR, fan 3m/s,

	pe	Cooling capacity				COP	EER	P1	I	m	
	[°C]	[°F]	[W]	[Btu/h]	[kcal/h]	[W/W]	[Btu/Wh]	[kcal/Wh]	[W]	[A]	[kg/h]
[°C / °F]	-20	-4	1242,6	4244	1069,4	1,44	4,93	1,24	861,2	4,53	27,37
cond. pressure	-15	5	1603,5	5476	1380,0	1,66	5,66	1,43	967,2	4,98	35,51
pc= 45/113	-10	14	2026,2	6920	1743,8	1,90	6,47	1,63	1069,2	5,42	45,15
return gas temp.	-6,7	20	2343,6	8004	2016,9	2,06	7,05	1,78	1135,1	5,70	52,48
RGT= 32/90	-5	23	2520,0	8606	2168,7	2,16	7,36	1,86	1168,9	5,85	56,58
liquid temp	0	32	3094,3	10567	2663,0	2,44	8,33	2,10	1268,1	6,28	70,09
Tliq= 45/113	7,2	45	4081,3	13938	3512,4	2,89	9,86	2,48	1413,7	6,90	93,92
[°C / °F]	-20	-4	987,2	3371	849,6	1,11	3,78	0,95	892,9	4,66	24,37
cond. pressure	-15	5	1294,7	4422	1114,2	1,26	4,32	1,09	1024,2	5,23	32,15
pc= 55/131	-10	14	1651,9	5641	1421,6	1,44	4,91	1,24	1149,4	5,76	41,31
return gas temp	-6,7	20	1919,4	6555	1651,8	1,56	5,33	1,34	1229,4	6,11	48,27
RGT= 32/90	-5	23	2068,1	7063	1779,8	1,63	5,56	1,40	1270,0	6,28	52,16
liquid temp	0	32	2552,7	8718	2196,9	1,84	6,28	1,58	1387,9	6,79	65,03
Tliq= 55/131	7,2	45	3389,5	11576	2917,1	2,18	7,44	1,87	1556,5	7,52	87,89